

Fire-resistance test on fire collars protecting a concrete floor slab penetrated by services

Test Report

Author: Peter Gordon
Report number: FSP 2028
Date: 22 August 2019

Client: IG6 Pty Ltd as trustee for the IG6 IP Trust

Commercial-in-confidence



Inquiries should be address to:

Fire Testing and Assessments	Author	The Client
NATA Registered Laboratory	Infrastructure Technologies	IG6 Pty Ltd as trustee for the IG6
14 Julius Avenue	14 Julius Avenue	IP Trust
North Ryde, NSW 2113	North Ryde, NSW 2113	3 Skirmish Court
Telephone +61 2 9490 5444	Telephone +61 2 9490 5500	Victoria Point Qld 4165

Report Status and Revision History:

VERSION	STATUS	DATE	DISTRIBUTION	ISSUE NUMBER
Revision A	Draft for review	31/07/2019	CSIRO and The Client	FSP 2028
Revision B	Final for issue	22/08/2019	CSIRO and The Client	FSP 2028

Report Authorisation:

AUTHOR	REVIEWED BY	AUTHORISED BY
Peter Gordon	Glenn Williams	Brett Roddy
		
22 August 2019	22 August 2019	22 August 2019

Use of this Report

Use of Reports – Testing

This report is subject to binding obligations under which it was prepared. In particular, the Report must not be used:

- *as a means of endorsement; or*
- *in a company prospectus or notification to a Stock Exchange document for capital raising, without the prior written consent of CSIRO.*

The Report may be published verbatim and in full, provided that a statement is included on the publication that it is a copy of the Report issued by CSIRO.

Excerpts of the Report may not be published.

Use of Reports – Consultancy

This report is subject to binding obligations under which it was prepared. In particular, the Report may only be used for the following purposes:

- *the information in the Report may be used by the party that commissioned the Report for its internal business operations (but not licensing to third parties);*
- *the report may be copied for distribution within the organisation that commissioned the Report;*
- *copies of the Report (or extracts of the Report) may be distributed to contractors and agents of the organisation that commissioned the Report who have a need for the Report for its internal business operations. Any extracts of the Report distributed for this purpose must clearly note that the extract is part of a larger Report held by the organisation that commissioned the Report and which has been prepared by CSIRO.*

The name, trade mark or logo of the CSIRO must not be used without the prior written consent of CSIRO.

The Report must not be used as a means of endorsement without the prior written consent of CSIRO.

Copyright and disclaimer

© 2019 CSIRO To the extent permitted by law, all rights are reserved and no part of this publication covered by copyright may be reproduced or copied in any form or by any means except with the written permission of CSIRO.

Important disclaimer

CSIRO advises that the information contained in this publication comprises general statements based on scientific research. The reader is advised and needs to be aware that such information may be incomplete or unable to be used in any specific situation. No reliance or actions must therefore be made on that information without seeking prior expert professional, scientific and technical advice. To the extent permitted by law, CSIRO (including its employees and consultants) excludes all liability to any person for any consequences, including but not limited to all losses, damages, costs, expenses and any other compensation, arising directly or indirectly from using this publication (in part or in whole) and any information or material contained in it.

Contents

1	Introduction	5
1.1	Identification of specimen	5
1.2	Sponsor	5
1.3	Manufacturer	5
1.4	Test standard	5
1.5	Reference standard.....	5
1.6	Test number.....	5
1.7	Test date	6
2	Description of specimen	6
2.1	General.....	6
2.2	Dimensions	7
2.3	Orientation.....	7
2.4	Conditioning.....	8
2.5	Selection, construction and installation of the specimen and the supporting construction	8
3	Documentation	8
4	Equipment.....	8
4.1	Furnace	8
4.2	Temperature	8
4.3	Measurement system	9
5	Ambient temperature	9
6	Departure from standard	9
7	Termination of test	9
8	Test results	9
8.1	Critical observations	9
8.2	Furnace temperature.....	10
8.3	Furnace severity.....	10
8.4	Specimen temperature.....	10
8.5	Performance	10
9	Fire-resistance level (FRL)	11
10	Field of direct application of test results	11
11	Tested by.....	11
	Appendices	12
	Appendix A – Measurement location	12
	Appendix B – Photographs.....	13
	Appendix C – Test Data Sheets.....	19
	Appendix D – Installation drawings.....	24
	Appendix E – Specimen Drawings	28
	Appendix F – Certificate(s) of Test	31
	References.....	34

Fire-resistance test on fire collars protecting a concrete floor slab penetrated by services

Sponsored Investigation No. FSP 2028

1 Introduction

1.1 Identification of specimen

The sponsor identified the specimen as five (5) cast-in fire collars protecting a 120-mm thick concrete floor slab penetrated by three (3) floor wastes and two (2) stack pipes.

1.2 Sponsor

IG6 Pty Ltd as trustee for the IG6 IP Trust
3 Skirmish Court
Victoria Point Qld 4165

1.3 Manufacturer

Snap Fire Systems Pty Ltd
Building A, 1343 Wynnum Road
Tingalpa QLD 4173

1.4 Test standard

Australian Standard 1530, Methods for fire tests on building materials, components and structures, Part 4-2014, Fire-resistance tests of elements of construction.

Section 10: Service penetrations and control joints

1.5 Reference standard

Australian Standard 4072, Components for the protection of openings in fire-resistant separating elements, Part 1 - 2005, Service penetrations and control joints.

1.6 Test number

CSIRO Reference test number: FS 4901/4417

1.7 Test date

The fire-resistance test was conducted on 30 July 2019.

2 Description of specimen

2.1 General

The specimen comprised an 1150-mm x 1150-mm x 120-mm thick concrete slab penetrated by three (3) floor wastes and two (2) stack pipes protected by five Snap Fire Systems Cast-in fire collars.

The penetrated slab comprised a 120-mm thick concrete slab reinforced with a single layer of steel reinforcement providing a Fire Resistance Period (FRP) for insulation of 120 minutes in accordance with table 5.5.1 of AS 3600:2018 - Concrete structures.

The pipes used in the test are stated to be manufactured in accordance with:

- AS/NZS 1260 PVC-U pipes and fittings for drain, waste and vent application;
- AS/NZS 4401 Plastics piping systems for soil and waste discharge (low and high temperature) inside buildings - Polyethylene (PE);
- AS/NZS 5065:2005 Polyethylene and polypropylene pipes and fittings for drainage and sewerage applications, and
- AS/NZS 7671:2010 Plastics piping systems for soil and waste discharge (low and high temperature) inside buildings— Polypropylene (PP).

For the purpose of the test, the specimens were referenced as Specimen 1, 2, 3, 4 and 5. Only three (3) specimens are the subject of this report (Specimens 3, 4 and 5). Documents containing a complete description of each specimen were supplied by the sponsor and are retained on file.

Specimen 3 – SNAP H50S-RR Cast-in collar protecting a nominal 40-mm HDPE (PE80) stack pipe.

The SNAP Cast-in H50S-RR fire collar comprised a 1.6-mm thick polypropylene casing with a 67-mm inner diameter and a 150-mm diameter base flange. The 250-mm high collar casing incorporated a 230-mm x 55-mm x 5-mm thick Intumesh intumescent material and a rubber ring seal. The closing mechanism comprised three galvanised steel springs bound with nylon fuse links and a 268-mm x 53-mm 316 stainless steel mesh as shown in drawing numbered H50S-RR-T dated 29 September 2017, by Snap Fire Systems Pty Ltd.

The penetrating service comprised a 40.5-mm outside diameter HDPE pipe with a wall thickness of 3.68-mm through the collar's sleeve. The annular gap between the pipe and the inside collar was protected with a bead of Fullers Firesound sealant as shown in titled "Specimen #3 40 HDPE Stack & H50S-RR", dated 15 July 2019, provided by Snap Fire Systems Pty Ltd. The pipe projected vertically, 2000-mm above from the unexposed face of the concrete slab and 500-mm into the furnace chamber. The pipe was supported at nominally 500-mm and 1500-mm from the unexposed face of the slab. The pipe was open at the unexposed end and capped with Superwool ceramic fibre plug on the exposed end.

Specimen 4 – SNAP H100S-RR Cast-in collar protecting a nominal 110-mm HDPE (PE100) stack pipe.

The SNAP Cast-in H100S-RR fire collar comprised a 1.6-mm thick polypropylene casing with a 126.5-mm inner diameter and a 213-mm diameter base flange. The 250-mm high collar casing incorporated a 412-mm x 85-mm x 4-mm thick Intumesh intumescent material and a rubber ring seal. The closing mechanism comprised three equally spaced 3.15-mm diameter galvanised steel springs bound with nylon fuse links acting against a 460-mm x 83-mm 316 stainless steel mesh as shown in drawing numbered H100S-RR-T dated 29 September 2017, by Snap Fire Systems Pty Ltd.

The penetrating service comprised a 110-mm outside diameter HDPE pipe with a wall thickness of 4.97-mm through the collar's sleeve. The annular gap between the pipe and the inside collar was protected with a bead of Fullers Firesound sealant as shown in drawing titled "Specimen #4 110 HDPE Stack & H100S-RR", dated 15 July 2019, provided by Snap Fire Systems Pty Ltd. The pipe projected vertically, 2000-mm above from the unexposed face of the concrete slab and 500-mm into the furnace chamber. The pipe was supported at nominally 500-mm and 1500-mm from the unexposed face of the slab. The pipe was open at the unexposed end and capped with Superwool ceramic fibre plug on the exposed end.

Specimen 5 – SNAP H100FWS-RR Cast-in fire collar protecting a nominal 110-mm polyvinyl chloride sandwich construction (PVC-SC) floor waste incorporating a 4-way riser with Soundlag 4525C lagging.

The SNAP Cast-in H100FWS-RR fire collar comprised a 1.6-mm thick polypropylene casing with a 126.5-mm inner diameter and a 213-mm base flange. The 250-mm high collar casing incorporated a layer of 412-mm x 85-mm x 4-mm thick Intumescent material. The closing mechanism comprised three equally spaced 3 steel springs held with nylon fuse links. The springs were fabricated using 304 grade stainless steel wire with a diameter of 3.15-mm, with the springs acting against a layer of 316 grade stainless steel mesh measuring 460 x 83-mm as shown in drawing numbered H100FWS-RR-T dated 29 September 2017, by Snap Fire Systems Pty Ltd.

The penetrating service comprised a 110-mm outside diameter polyvinyl chloride (PVC) sandwich construction pipe with a wall thickness of 3.7-mm fitted through the collar's sleeve. The floor waste system was fitted with a chrome brass grate and ABS Puddle Flange. A 15-mm thick grout screed was laid on top of the concrete slab and finished flush with the floor grate. On the exposed side of the slab, a 4-way riser was connected to the penetrating pipe, supported by two M10 threaded rod and steel drop-in anchor to the concrete slab. On the exposed face, the 4-way riser was capped using a polyvinyl chloride sandwich construction end cap. The 4-way riser was then lagged with Pyrotec Soundlag 4525C fixed using Tesa foil tape. The floor waste gully was charged with water to the level shown in drawing titled "Specimen #5 100 PVC(SC) FWS, Lagging & H100FWS-RR", dated 15 July 2019, provided by Snap Fire Systems Pty Ltd.

2.2 Dimensions

The specimen comprised an 1150-mm x 1150-mm x 120-mm thick concrete slab to suit the opening in the specimen containing frame.

2.3 Orientation

The reinforced concrete slab was placed horizontally on top of the furnace chamber, and subjected to fire exposure from the underside.

2.4 Conditioning

The concrete slab was left to cure for a period longer than 30 days.

2.5 Selection, construction and installation of the specimen and the supporting construction

The supporting floor construction and specimen installation was organised by the sponsor. CSIRO was not involved in the selection of the materials.

3 Documentation

The following documents were supplied or referenced by the sponsor as a complete description of the specimen and should be read in conjunction with this report:

- Technical brochure titled “Pyrotek-SOUNDLAG-BROCHURE” by Pyrotek dated January 2017.
- Drawing titled “Test Slab S-19-F Layout”, dated 8 May 2019 provided by Snap Fire Systems Pty Ltd.
- Drawing titled “Specimen #3 40 HDPE Stack & H50S-RR”, dated 15 July 2019, provided by Snap Fire Systems Pty Ltd.
- Drawing titled “Specimen #4 110 HDPE Stack & H100S-RR”, dated 15 July 2019, provided by Snap Fire Systems Pty Ltd.
- Drawing titled “Specimen #5 100 PVC(SC) FWS, Lagging & H100FWS-RR”, dated 15 July 2019, provided by Snap Fire Systems Pty Ltd.
- Drawing number H100S-RR-T, dated 29 September 2017, by Snap Fire Systems Pty Ltd.
- Drawing number H100FWS-RR-T, dated 29 September 2017, by Snap Fire Systems Pty Ltd.
- Drawing number H50S-RR-T, dated 29 September 2017, by Snap Fire Systems Pty Ltd.

4 Equipment

4.1 Furnace

The furnace had a nominal opening of 1000-mm x 1000-mm for attachment of vertical or horizontal specimens.

The furnace was lined with refractory bricks and materials with the thermal properties as specified in AS 1530.4-2014 and was heated by combustion of a mixture of natural gas and air.

4.2 Temperature

The temperature in the furnace chamber was measured by four type K, 3-mm diameter, and 310 stainless steel Mineral Insulated Metal Sheathed (MIMS) thermocouples. Each thermocouple was housed in high-nickel steel tubes opened at the exposed end.

The temperatures of the specimen were measured by glass-fibre insulated and sheathed K-type thermocouples with a wire diameter of 0.5-mm.

Location of the thermocouples on the unexposed face of the specimen are described in Appendix A.

4.3 Measurement system

The primary measurement system comprised a multiple-channel data logger, scanning at one minute intervals during the test.

5 Ambient temperature

The temperature of the test area was 15°C at the commencement of the test.

6 Departure from standard

There were no departures from the requirements of AS 1530.4-2014.

7 Termination of test

The test was terminated at 241 minutes by the agreement with the sponsor.

8 Test results

8.1 Critical observations

The following observations were made during the fire-resistance test:

Time	Observation
2 minutes -	Smoke is fluing from the end of pipe of Specimen 3.
3 minutes -	Smoke is emitting form the end of the pipe of Specimen 4.
4 minutes -	Smoke has ceased fluing from Specimen 3.
5 minutes -	Cotton wool pad test applied above the grate of Specimen 5 floor waste. No ignition noted at this time.
10 minutes -	Smoke level fluing from Specimen 4 has reduced.
20 minutes -	Moisture has formed around the base of Specimens 3 and 4.
26 minutes -	Steam is being emitted from the concrete around the base of Specimens 3 and 4.
45 minutes -	Intumescent sealant around the base of Specimen 3 has begun to swell.
65 minutes -	Moisture pooling on the top of the slab have has evaporated, however steam continues to be emitted.
80 minutes -	Intumescent sealant around the base of Specimen 4 has begun to swell.
140 minutes -	Intumescent sealant around the base of Specimens 3 and 4 continues to swell.
151 minutes -	<u>Insulation failure of Specimen 3</u> - maximum temperature rise of 180K is exceeded on the slab 25-mm from mastic on the unexposed face.

- 154 minutes - Insulation failure of Specimen 4 - maximum temperature rise of 180K is exceeded on the slab 25-mm from mastic on the unexposed face.
- 170 minutes - Insulation failure of Specimen 5 - maximum temperature rise of 180K is exceeded on the centre of the grate on the unexposed face.
- 241 minutes - Test terminated.

8.2 Furnace temperature

Figure 1 shows the standard curves of temperature versus time for heating the furnace chamber and the actual curves of average and maximum temperature versus time recorded during the heating period.

8.3 Furnace severity

Figure 2 shows the curve of furnace severity versus time during the heating period.

8.4 Specimen temperature

Figure 3 shows the curve of temperature versus time associated with Specimen 3.

Figure 4 shows the curve of temperature versus time associated with Specimen 4.

Figure 5 shows the curve of temperature versus time associated with Specimen 5.

8.5 Performance

Performance observed in respect of the following AS 1530.4-2014 criteria:

Specimen 3 – SNAP H50S-RR Cast-in collar protecting a nominal 40-mm HDPE (PE80) stack pipe.

Structural adequacy	-	not applicable
Integrity	-	no failure at 241 minutes
Insulation	-	151 minutes

Specimen 4 – SNAP H100S-RR Cast-in collar protecting a nominal 110-mm HDPE (PE100) stack pipe.

Structural adequacy	-	not applicable
Integrity	-	no failure at 241 minutes
Insulation	-	155 minutes

Specimen 5 – SNAP H100FWS-RR Cast-in fire collar protecting a nominal 110-mm polyvinyl chloride sandwich construction (PVC-SC) floor waste incorporating a 4-way riser with Soundlag 4525C lagging.

Structural adequacy	-	not applicable
Integrity	-	no failure at 241 minutes
Insulation	-	170 minutes

This report details methods of construction, the test conditions and the results obtained when the specific element of construction described herein was tested following the procedure outlined in this standard. Any significant variation with respect to size, constructional details, loads, stresses, edge or end conditions, other than those allowed under the field of direct application in the relevant test method, is not covered by this report.

Because of the nature of fire resistance testing and the consequent difficulty in quantifying the uncertainty of measurement of fire resistance, it is not possible to provide a stated degree of accuracy of the result.

9 Fire-resistance level (FRL)

For the purpose of building regulations in Australia, the FRL's of the test specimens were as follows:

Specimen 3:	-/120/120
Specimen 4:	-/120/120
Specimen 5:	-/120/120

The fire-resistance level of the specimen is applicable when the system is exposed to fire from the same direction as tested.

For the purposes of AS 1530.4-2014 the results of these fire tests may be used to directly assess fire hazard, but it should be noted that a single test method will not provide a full assessment of fire hazard under all fire conditions.

10 Field of direct application of test results

The results of the fire test contained in this test report are directly applicable, without reference to the testing authority, to similar constructions where one or more changes listed in Clause 10.11 of AS 1530.4-2014, have been made provided no individual component is removed or reduced.

11 Tested by



Peter Gordon
Testing Officer

Appendices

Appendix A – Measurement location

Specimen	T/C Position	T/C designation
SPECIMEN 3 – Geberit PE80 40.5-mm OD x 3.68-mm thick stack pipe protected with a H50S-RR Cast-in fire collar. The annular gap around the pipe on the exposed side was sealed with a 10-mm deep bead of Fullers Firesound mastic.	On top of the slab – 25-mm from Mastic (North)	S11
	On top of the slab – 25-mm from Mastic (West)	S12
	On Pipe 25-mm above mastic (West)	S13
	On Pipe 25-mm above mastic (East)	S14
SPECIMEN 4 – Vinidex PE110 110-mm OD x 4.97-mm thick stack pipe protected with a H100S-RR Cast-in fire collar. The annular gap around the pipe on the exposed side was sealed with a 10-mm deep bead of Fullers Firesound mastic.	On top of the slab – 25-mm from Mastic (North)	S15
	On top of the slab – 25-mm from Mastic (E/W)	S16
	On Pipe 25-mm from Mastic (North)	S17
	On Pipe 25-mm from Mastic (East)	S18
SPECIMEN 5 – Ipex PVC-SC pipe 100-mm OD x 3.7-mm wall thickness pipe with a floor waste and 4-Way riser protected with a H100FWS cast-in fire collar and Soundlag 4525C insulation.	On top of the slab – 25-mm from screed (North)	S19
	On top of the slab – 25-mm from screed (West)	S20
	On Screed 25-mm from Grate (North)	S21
	On Screed 25-mm from Grate (South)	S22
	On centre of the Grate	S23
Rover	Rover	S24
Ambient	Ambient	S25

Appendix B – Photographs



PHOTOGRAPH 1 – EXPOSED FACE OF SPECIMENS PRIOR TO TESTING



PHOTOGRAPH 2 – UNEXPOSED FACE OF SPECIMENS PRIOR TO TESTING



PHOTOGRAPH 3 – SPECIMENS AFTER 30 MINUTES OF TESTING



PHOTOGRAPH 4 – SPECIMENS AFTER 60 MINUTES OF TESTING

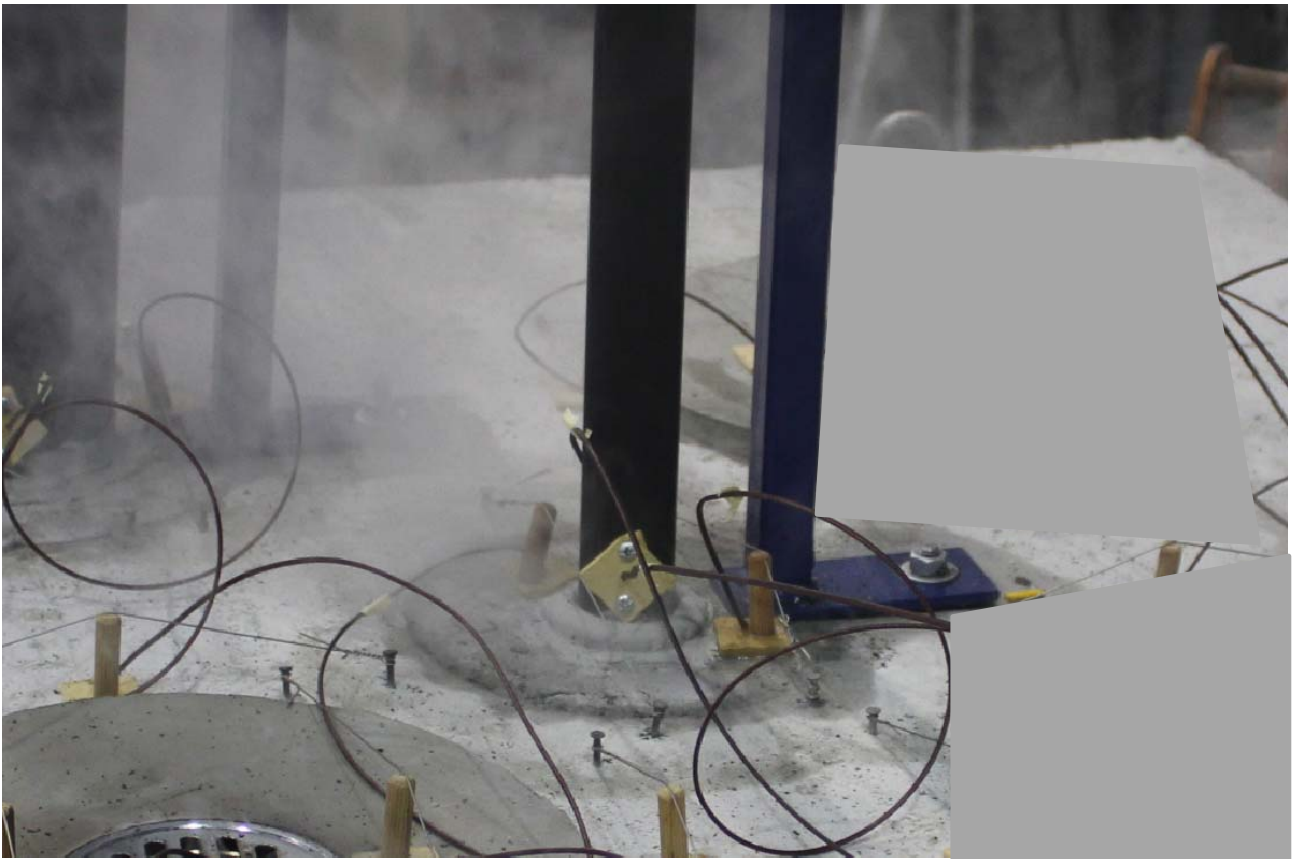

PHOTOGRAPH 5 – SPECIMEN 3 AFTER 62 MINUTES OF TESTING



PHOTOGRAPH 6 – SPECIMENS AFTER 90 MINUTES OF TESTING



PHOTOGRAPH 7 – SPECIMENS AFTER 120 MINUTES OF TESTING

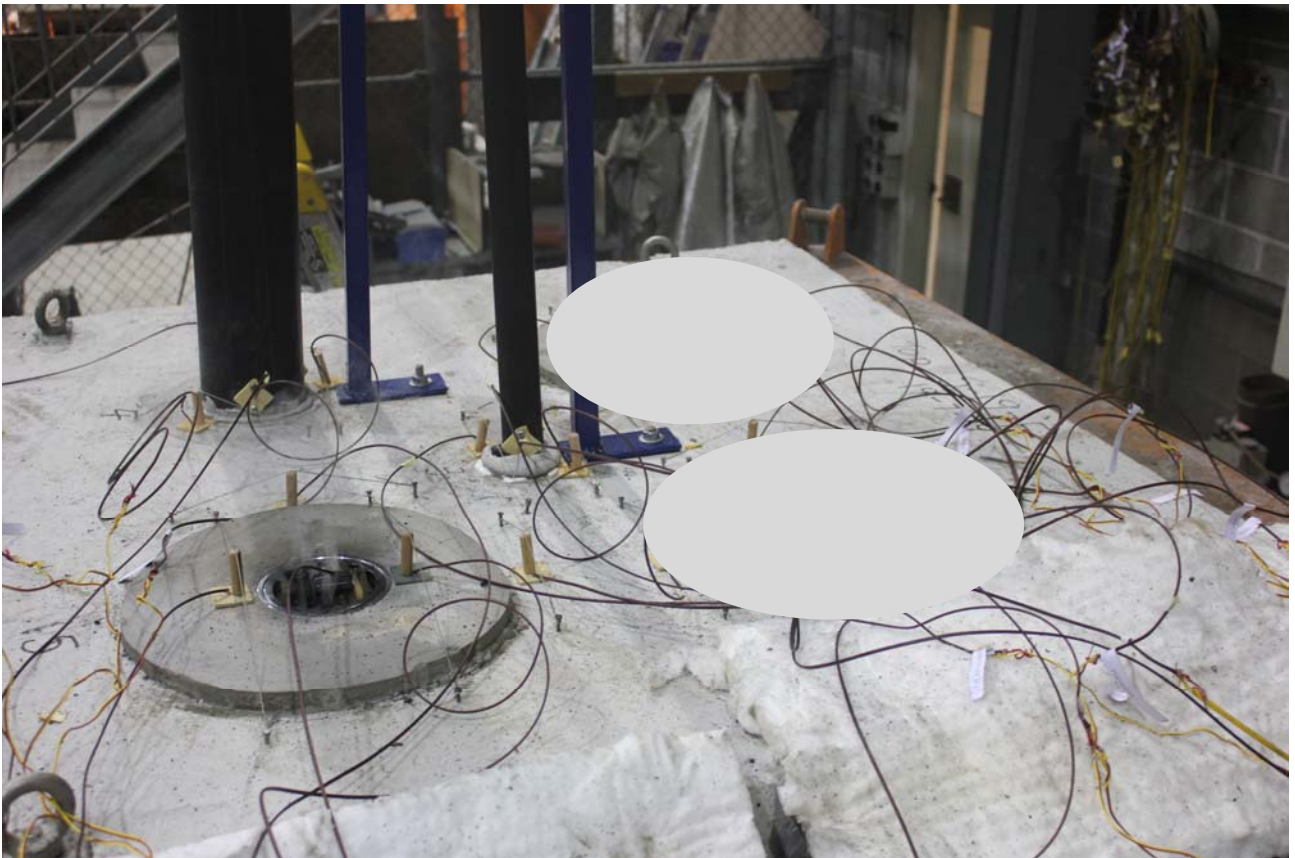

PHOTOGRAPH 8 – SPECIMENS AFTER 150 MINUTES OF TESTING

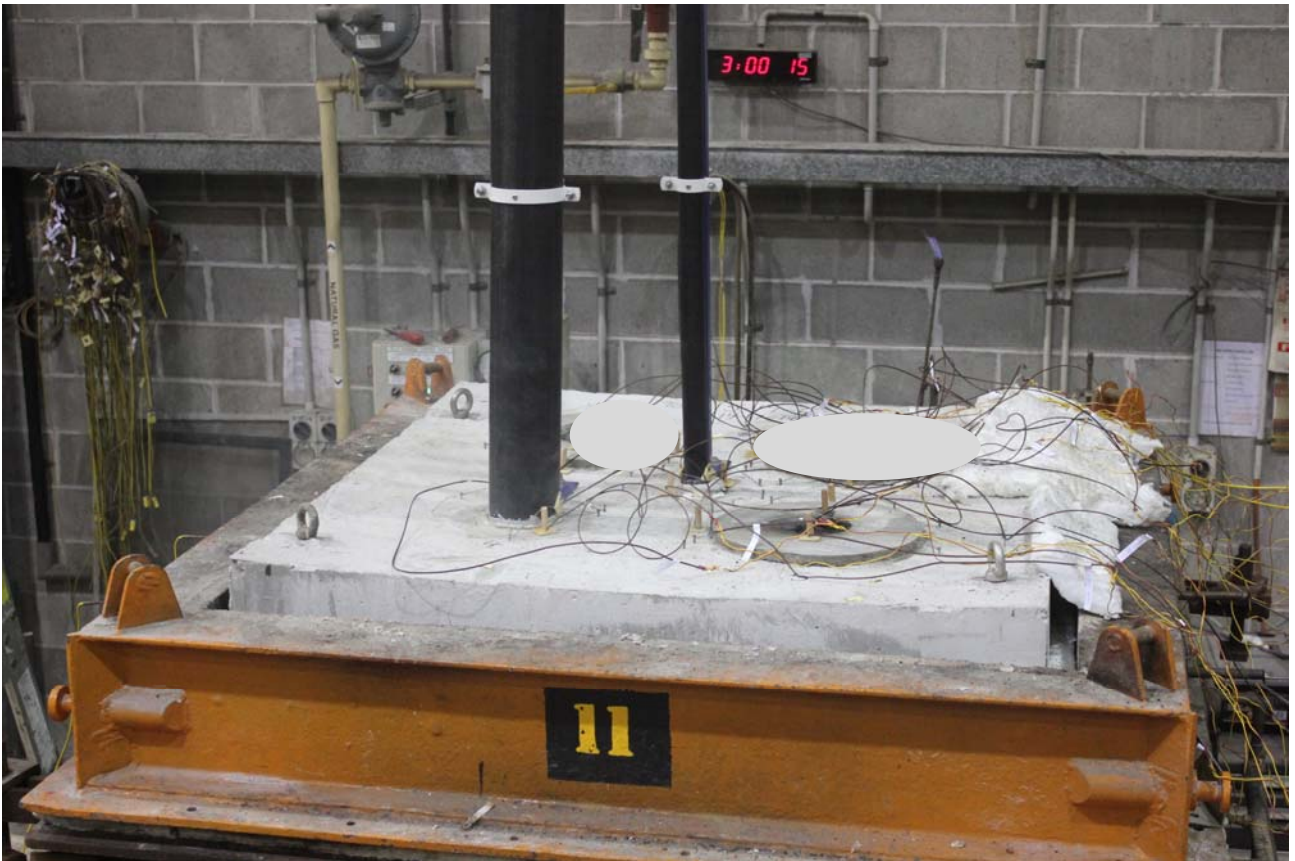

PHOTOGRAPH 9 – SPECIMENS AFTER 180 MINUTES OF TESTING



PHOTOGRAPH 10 – SPECIMENS AFTER 240 MINUTES OF TESTING

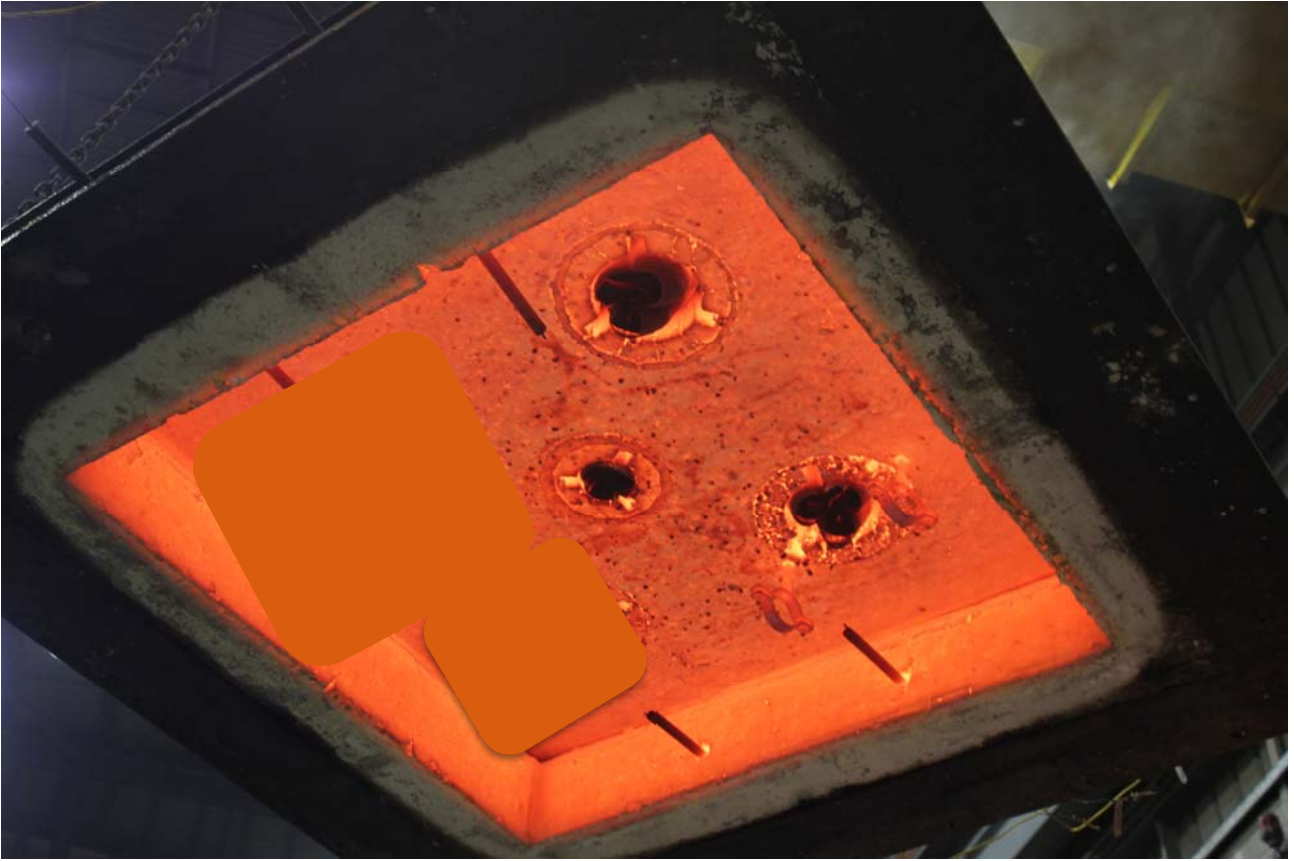

PHOTOGRAPH 10 – EXPOSED FACE OF SPECIMENS AT THE CONCLUSION OF TESTING

Appendix C – Test Data Sheets

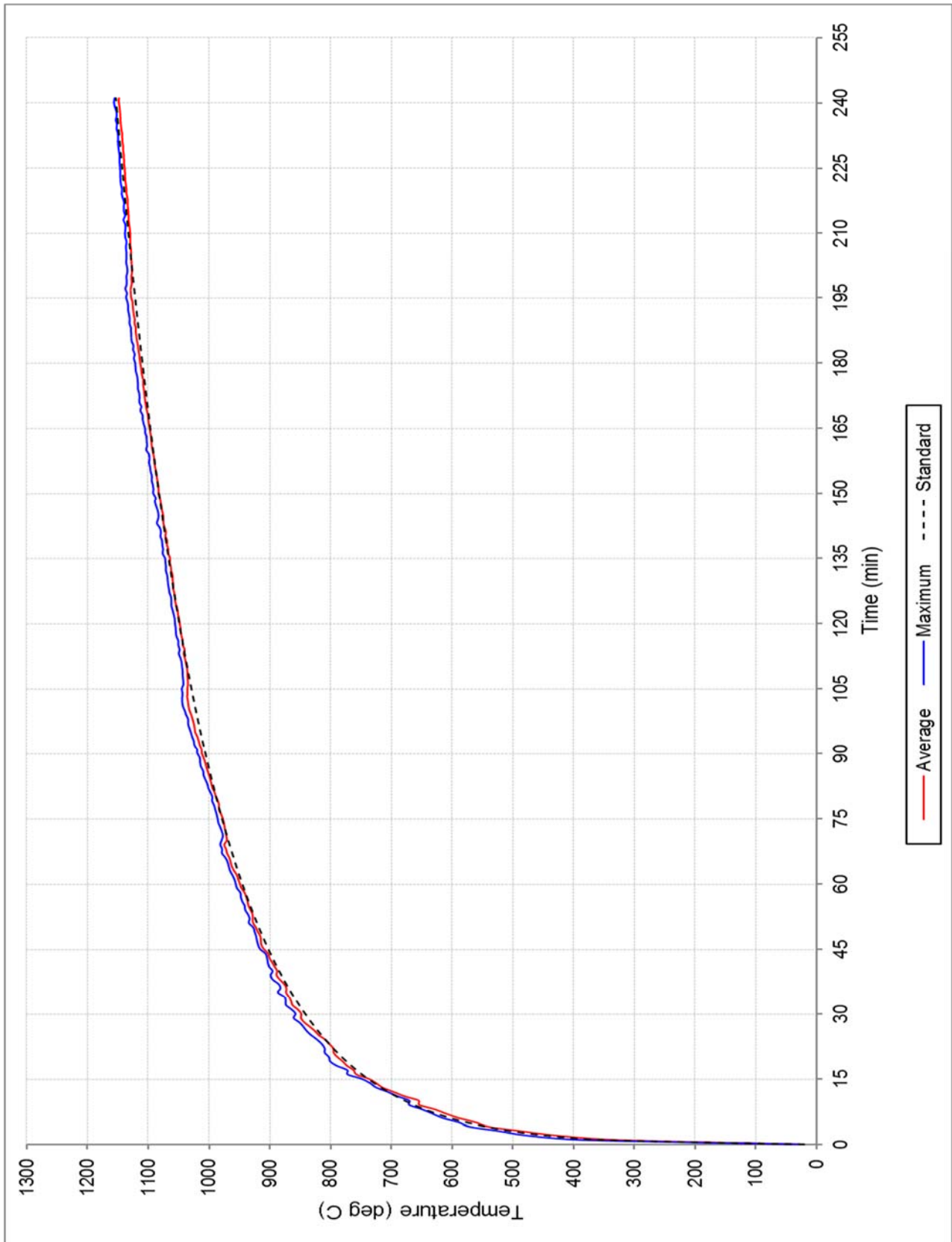

FIGURE 1 – FURNACE TEMPERATURE

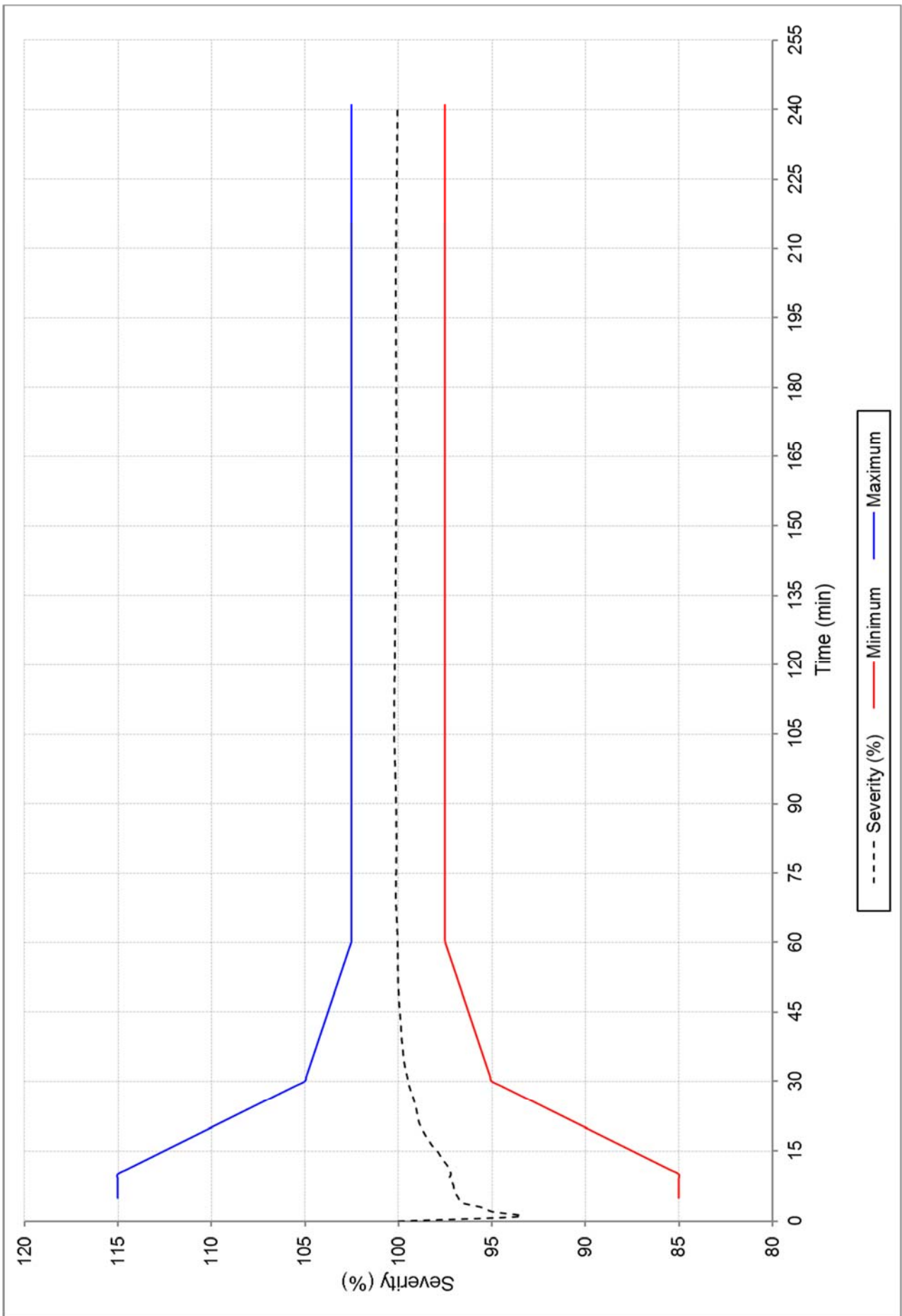

FIGURE 2 – FURNACE SEVERITY

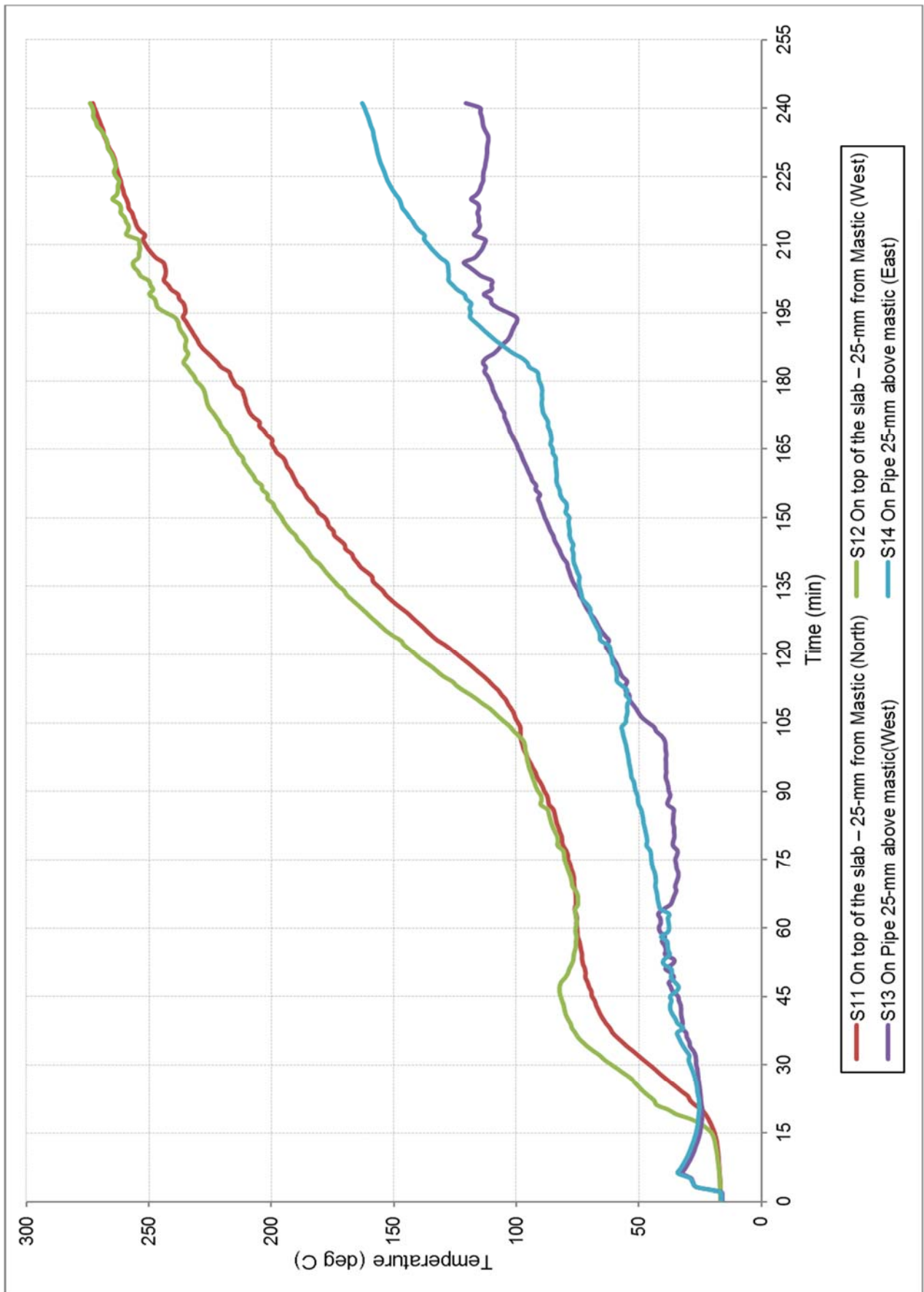

FIGURE 3 – SPECIMEN TEMPERATURE – ASSOCIATED WITH SPECIMEN 3

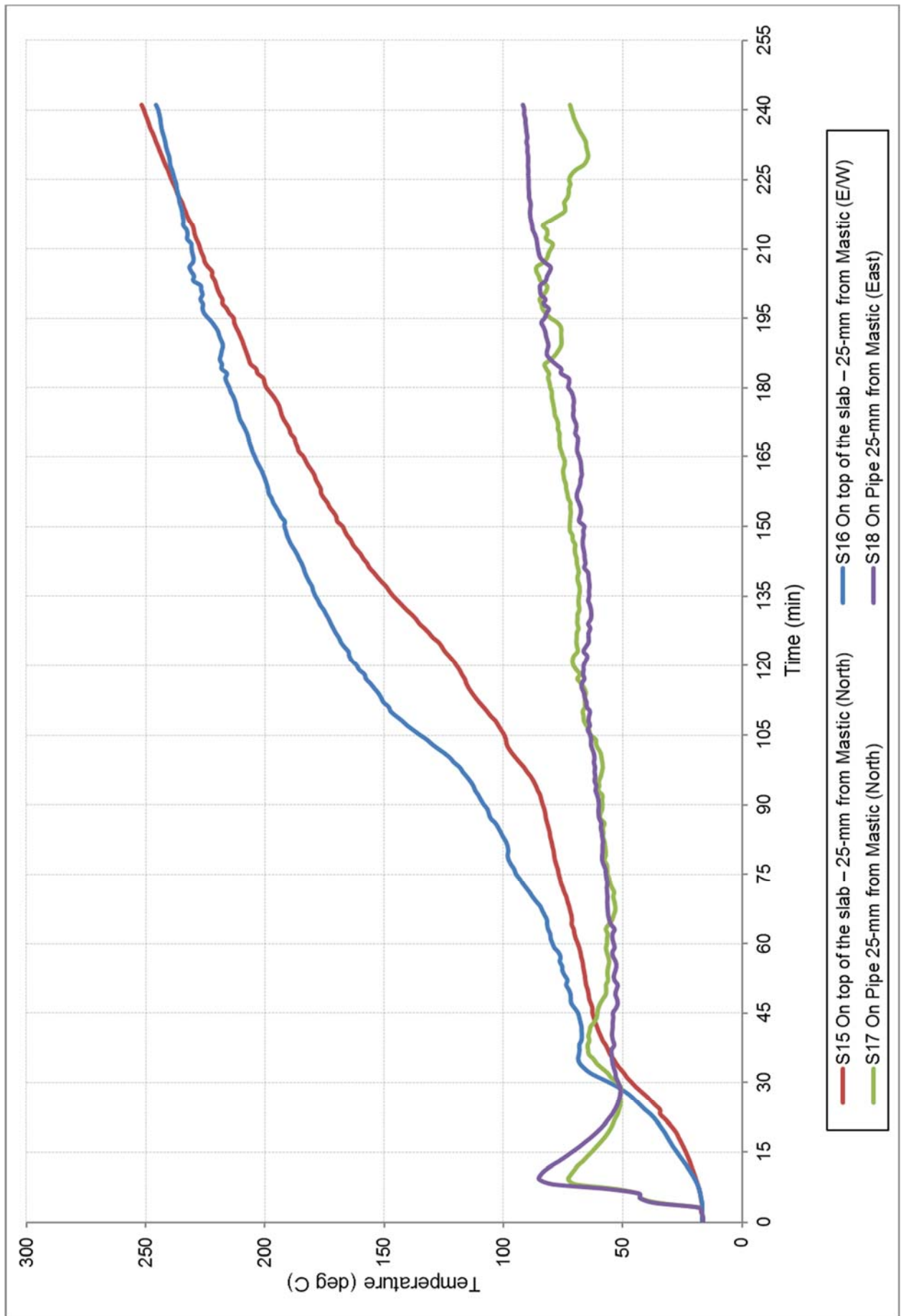

FIGURE 4 – SPECIMEN TEMPERATURE – ASSOCIATED WITH SPECIMEN 4

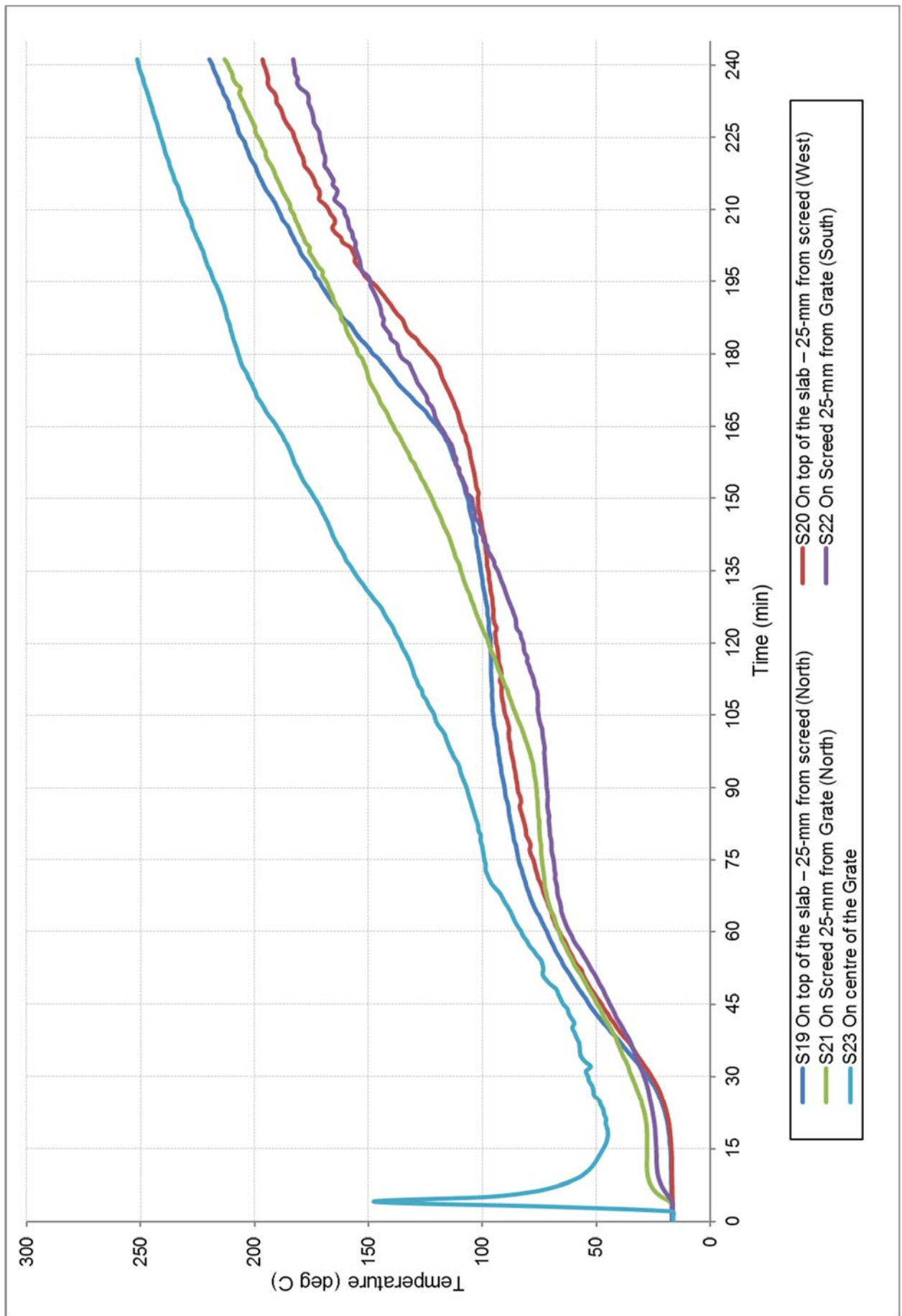
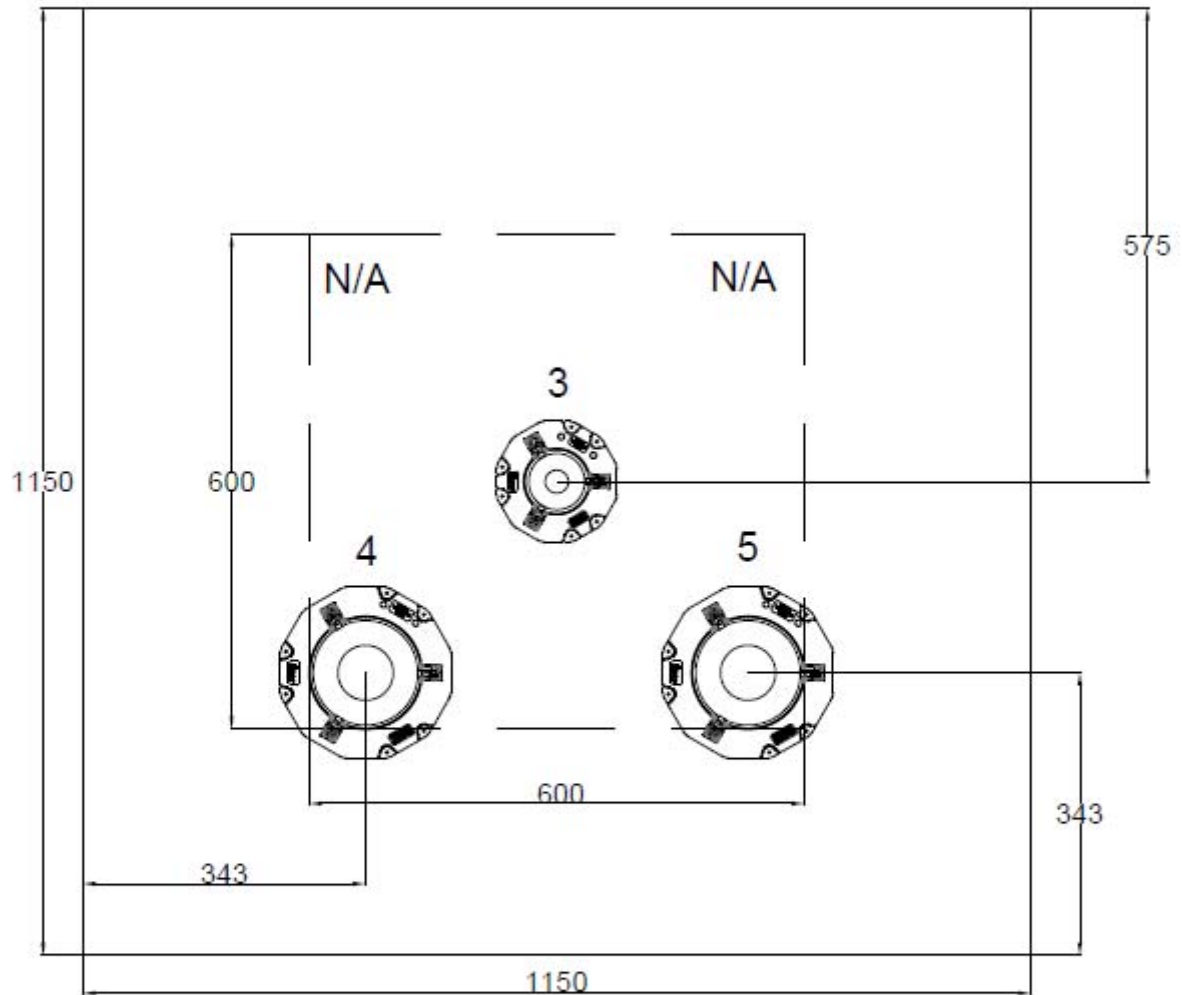

FIGURE 5 – SPECIMEN TEMPERATURE – ASSOCIATED WITH SPECIMEN 5

Appendix D – Installation drawings

Snap Fire Systems Pty Ltd
 Test Slab S-19-F Layout
 Date: 08 MAY 2019



Penetration	Collar Code	Pipe Type	Pipe Diameter (mm)	Fitting
3	H50S	HDPE	40	N/A
4	H100S	HDPE	110	N/A
5	H100FWS	PVC-SC	100	N/A

DRAWING TITLED “TEST SLAB S-19-F LAYOUT”, DATED 8 MAY 2019, PROVIDED BY SNAP FIRE SYSTEMS PTY LTD

Snap Fire Systems Pty Ltd

Specimen #3

40 HDPE Stack & H50S-RR

Date: 15 JULY 2019

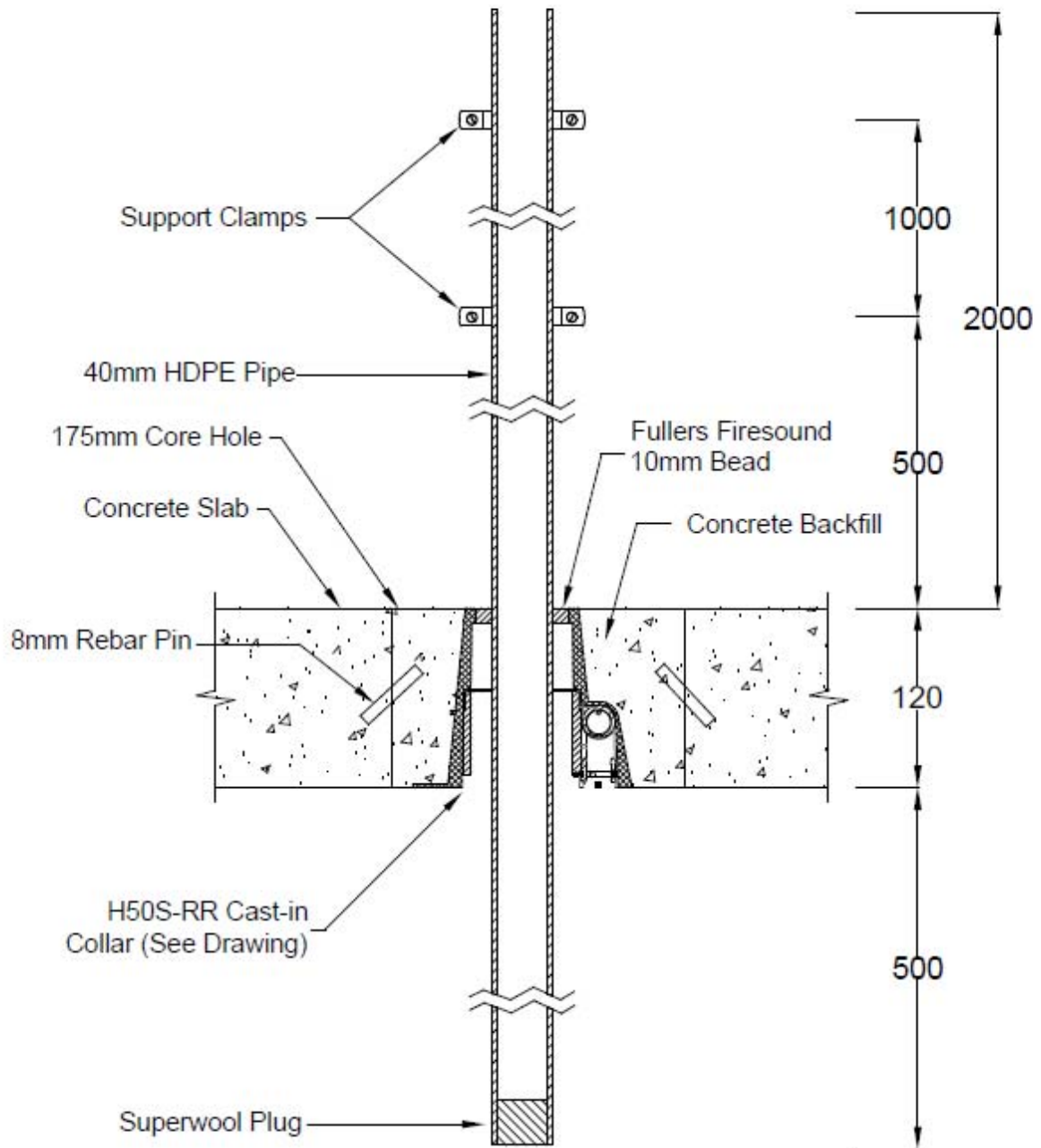

DRAWING TITLED "SPECIMEN # 3, 40 HDPE STACK & H50S-RR", DATED 15 JULY 2019, PROVIDED BY SNAP FIRE SYSTEMS PTY LTD

Snap Fire Systems Pty Ltd

Specimen #4

110 HDPE Stack & H100S-RR

Date: 15 JULY 2019

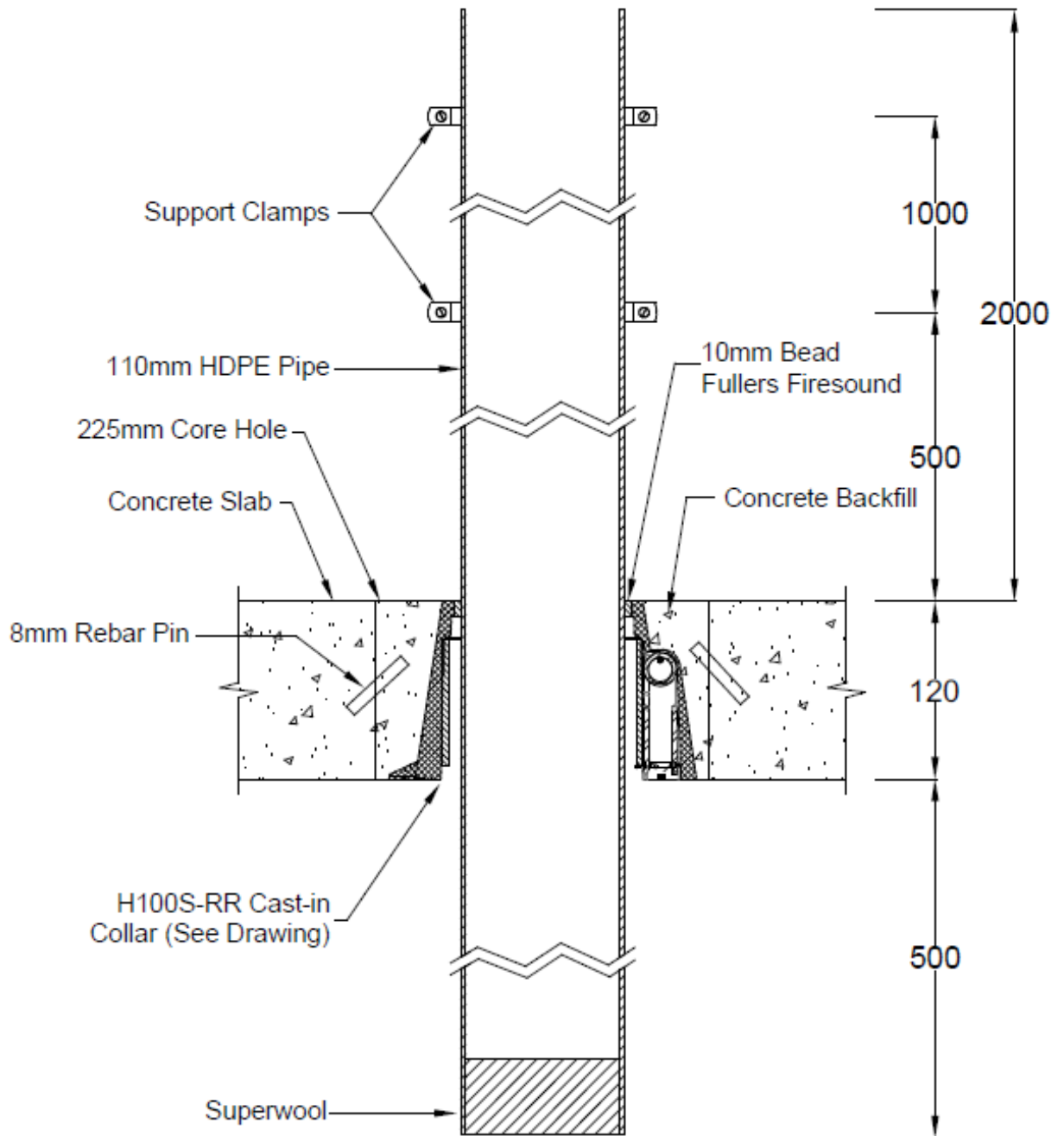

DRAWING TITLED "SPECIMEN # 4, 110 HDPE STACK & H100S-RR", DATED 15 JULY 2019, PROVIDED BY SNAP FIRE SYSTEMS PTY LTD

Snap Fire Systems Pty Ltd

Specimen #5

100 PVC(SC) FWS, Lagging & H100FWS-RR

Date: 15 JULY 2019

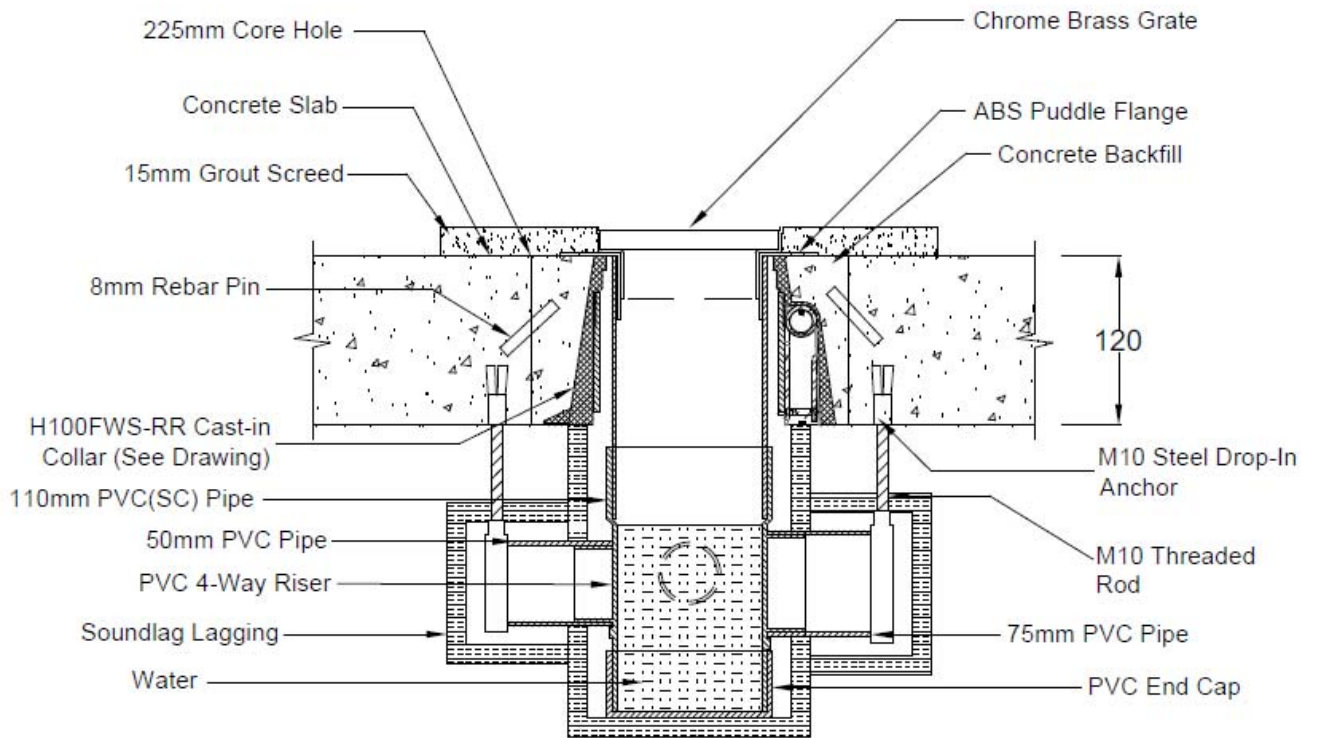

DRAWING TITLED "SPECIMEN #5, 100 PVC(SC) FWS, LAGGING & H100FWS-RR", DATED 15 MAY 2019, PROVIDED BY SNAP FIRE SYSTEMS PTY LTD

Appendix E – Specimen Drawings

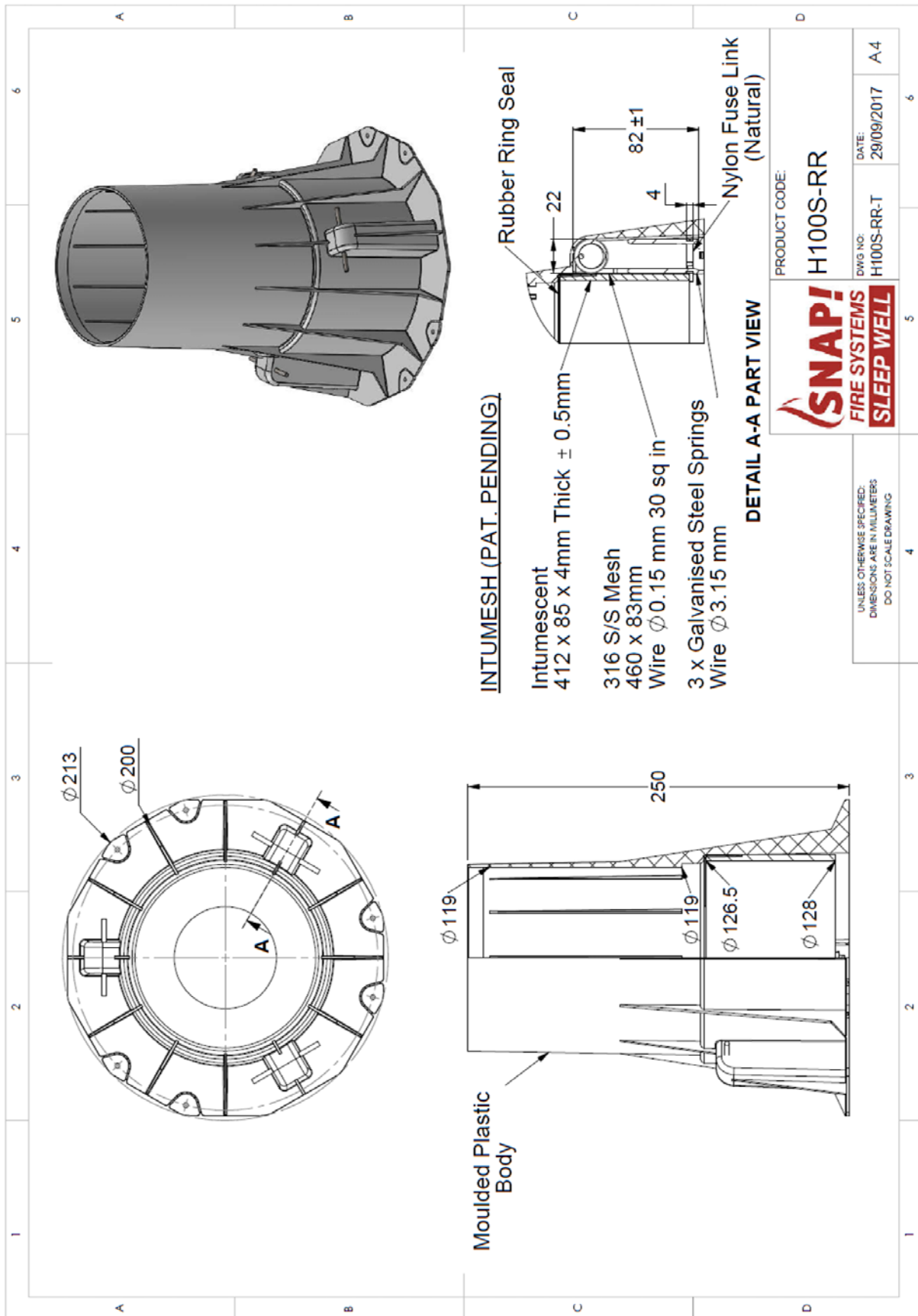

DRAWING NUMBER H100S-RR-T, DATED 29 SEPTEMBER 2017, BY SNAP FIRE SYSTEMS PTY LTD.

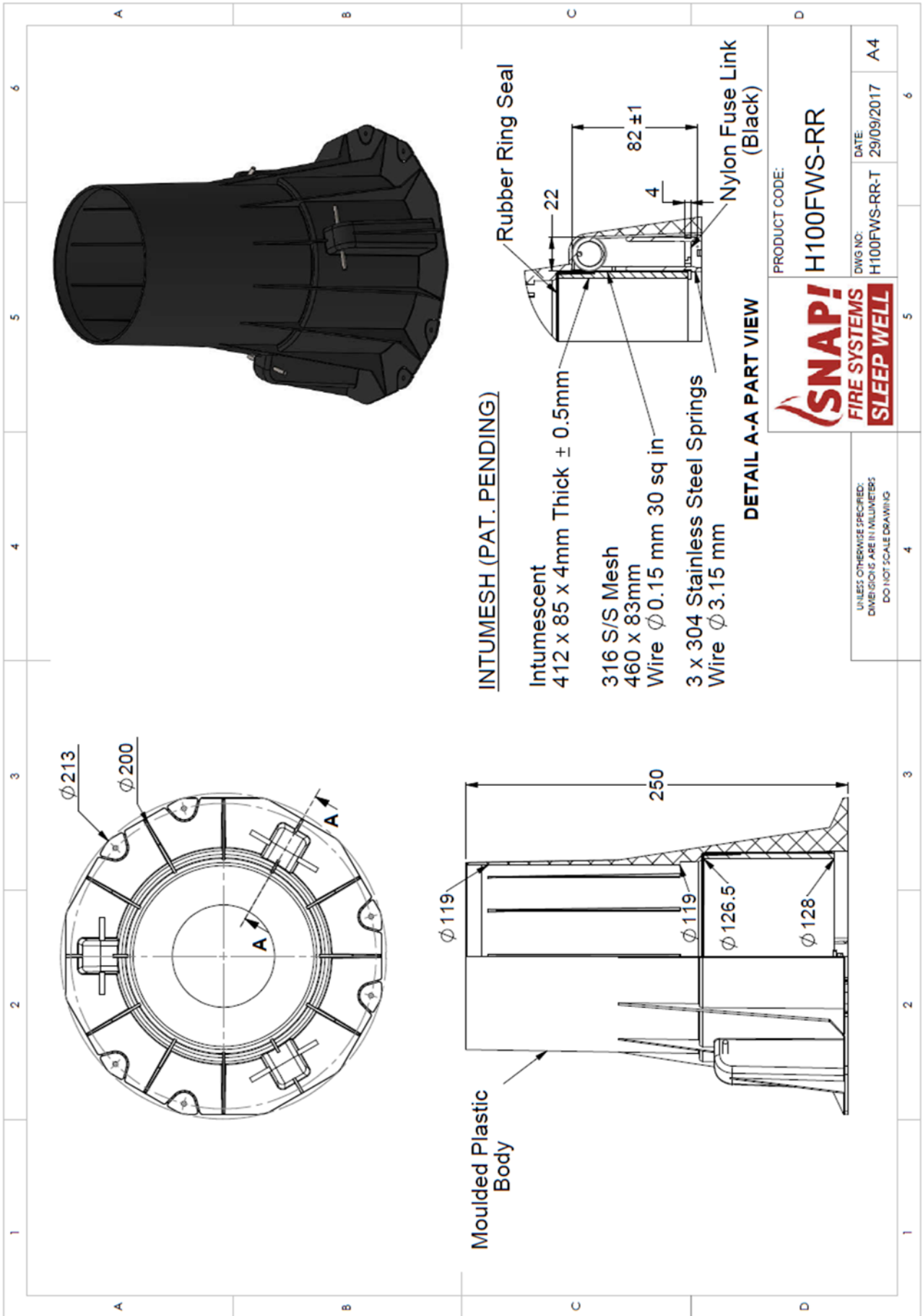

INTUMESH (PAT. PENDING)

- Intumescent
412 x 85 x 4mm Thick ± 0.5mm
- 316 S/S Mesh
460 x 83mm
- Wire Ø0.15 mm 30 sq in
- 3 x 304 Stainless Steel Springs
Wire Ø3.15 mm

DETAIL A-A PART VIEW



PRODUCT CODE:
H100FWS-RR

DWG NO:
H100FWS-RR-T

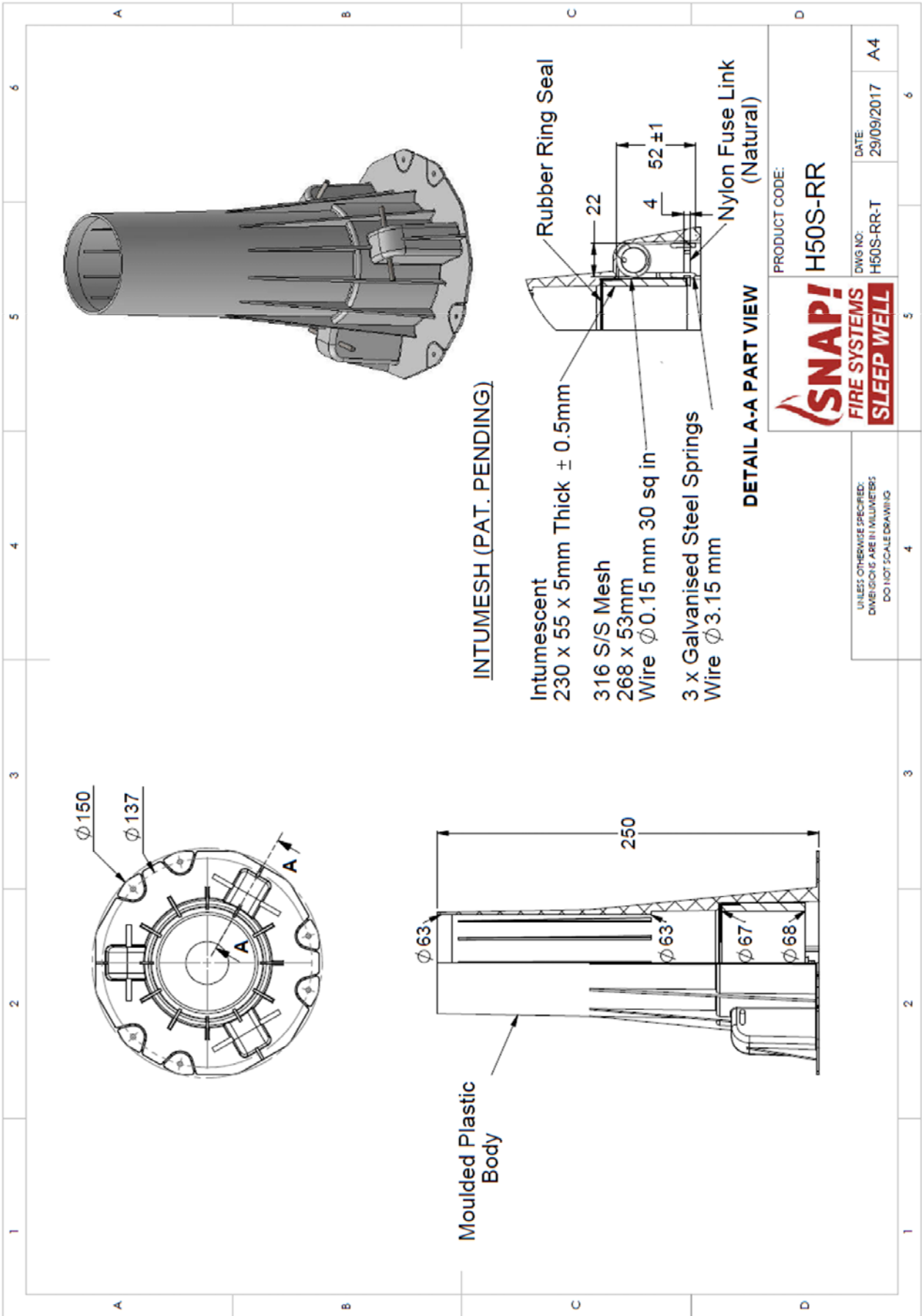

DATE:
29/09/2017

UNLESS OTHERWISE SPECIFIED:
DIMENSIONS ARE IN MILLIMETERS
DO NOT SCALE DRAWING



DRAWING NUMBER H50S-RR-T, DATED 29 SEPTEMBER 2017, BY SNAP FIRE SYSTEMS PTY LTD.

Appendix F – Certificate(s) of Test

INFRASTRUCTURE TECHNOLOGIES www.csiro.au		
14 Julius Avenue, North Ryde NSW 2113 PO Box 52, North Ryde NSW 1670, Australia T (02) 9490 5444 • ABN 41 687 119 230		
<h2>Certificate of Test</h2>		No. 3320
This is to certify that the element of construction described below was tested by CSIRO Infrastructure Technologies in accordance with Australian Standard 1530, Methods for fire tests on building materials, components and structures, Part 4 Fire-resistance tests of elements of construction, 2014, Section 10: Service penetrations and control joints, on behalf of:		
IG6 Pty Ltd as trustee for the IG6 IP Trust 3 Skirmish Court Victoria Point Qld 4165		
A full description of the test specimen and the complete test results are detailed in the Division's report numbered FSP 2028.		
Product Name: SNAP H50S-RR Cast-in collar protecting a nominal 40-mm HDPE (PE80) stack pipe (Specimen 3)		
Description:	The specimen comprised an 1150-mm x 1150-mm x 120-mm thick concrete slab penetrated by a stack pipe protected by a Snap Fire Systems Cast-in fire collar. The penetrated slab comprised a 120-mm thick concrete slab reinforced with a single layer of steel reinforcement providing a Fire Resistance Period (FRP) for insulation of 120 minutes in accordance with Table 5.5.1 of AS 3600:2018 - Concrete structures. The SNAP Cast-in H50S-RR fire collar comprised a 1.6-mm thick polypropylene casing with a 67 mm inner diameter and a 150-mm diameter base flange. The 250 mm high collar casing incorporated a 230-mm x 55-mm x 5-mm thick Intumesh intumescent material and a rubber ring seal. The closing mechanism comprised three galvanised steel springs bound with nylon fuse links and a 268-mm x 53-mm 316 stainless steel mesh as shown in drawing numbered H50S-RR-T dated 29 September 2017, by Snap Fire Systems Pty Ltd. The penetrating service comprised a 40.5-mm outside diameter HDPE pipe with a wall thickness of 3.68 mm through the collar's sleeve. The annular gap between the pipe and the inside collar was protected with a bead of Fullers Firesound sealant as shown in titled "Specimen #3 40 HDPE Stack & H50S-RR", dated 15 July 2019, provided by Snap Fire Systems Pty Ltd. The pipe projected vertically, 2000-mm above from the unexposed face of the concrete slab and 500-mm into the furnace chamber. The pipe was supported at nominally 500-mm and 1500-mm from the unexposed face of the slab. The pipe was open at the unexposed end and capped with Superwool ceramic fibre plug on the exposed end.	
Performance observed in respect of the following AS 1530.4-2014 criteria		
Structural Adequacy	-	not applicable
Integrity	-	no failure at 241 minutes
Insulation	-	151 minutes
and therefore for the purpose of Building Regulations in Australia, achieved a fire-resistance level (FRL) of -/120/120.		
The fire-resistance level of the specimen is applicable when the system is exposed to fire from the same direction as tested. For the purposes of AS 1530.4-2014 the results of these fire tests may be used to directly assess fire hazard, but it should be noted that a single test method will not provide a full assessment of fire hazard under all fire conditions. This certificate is provided for general information only and does not comply with regulatory requirements for evidence of compliance.		
Testing Officer:	Peter Gordon	Date of Test: 30 July 2019
Issued on the 22 nd day of August 2019 without alterations or additions.		
 Brett Roddy Manager, Fire Testing and Assessments		
"Copyright CSIRO 2019 ©" Copying or alteration of this report without written authorisation from CSIRO is forbidden		
	This document is issued in accordance with NATA's accreditation requirements. Accreditation No. 165 – Corporate Site No. 3625 Accredited for compliance with ISO/IEC 17025 - Testing	

COPY OF CERTIFICATE OF TEST – NO. 3320



Certificate of Test

No. 3321

This is to certify that the element of construction described below was tested by CSIRO Infrastructure Technologies in accordance with Australian Standard 1530, Methods for fire tests on building materials, components and structures, Part 4 Fire-resistance tests of elements of construction, 2014, Section 10: Service penetrations and control joints, on behalf of:

IG6 Pty Ltd as trustee for the IG6 IP Trust
3 Skirmish Court
Victoria Point Qld 4165

A full description of the test specimen and the complete test results are detailed in the Division's report numbered FSP 2028.

Product Name: SNAP H100S-RR Cast-in collar protecting a nominal 110-mm HDPE (PE100) stack pipe (Specimen 4)

Description: The specimen comprised an 1150-mm x 1150-mm x 120-mm thick concrete slab penetrated by a stack pipe protected by a Snap Fire Systems Cast-in fire collar. The penetrated slab comprised a 120-mm thick concrete slab reinforced with a single layer of steel reinforcement providing a Fire Resistance Period (FRP) for insulation of 120 minutes in accordance with Table 5.5.1 of AS 3600:2018 - Concrete structures. The SNAP Cast-in H100S-RR fire collar comprised a 1.6-mm thick polypropylene casing with a 126.5 mm inner diameter and a 213-mm diameter base flange. The 250 mm high collar casing incorporated a 412-mm x 85-mm x 4-mm thick Intumesh intumescent material and a rubber ring seal. The closing mechanism comprised three equally spaced 3.15-mm diameter galvanised steel springs bound with nylon fuse links acting against a 460-mm x 83-mm 316 stainless steel mesh as shown in drawing numbered H100S RR-T dated 29 September 2017, by Snap Fire Systems Pty Ltd. The penetrating service comprised a 110-mm outside diameter HDPE pipe with a wall thickness of 4.97 mm through the collar's sleeve. The annular gap between the pipe and the inside collar was protected with a bead of Fullers Firesound sealant as shown in drawing titled "Specimen #4 110 HDPE Stack & H100S-RR", dated 15 July 2019, provided by Snap Fire Systems Pty Ltd. The pipe projected vertically, 2000-mm above from the unexposed face of the concrete slab and 500-mm into the furnace chamber. The pipe was supported at nominally 500-mm and 1500-mm from the unexposed face of the slab. The pipe was open at the unexposed end and capped with Superwool ceramic fibre plug on the exposed end.

Performance observed in respect of the following AS 1530.4-2014 criteria

Structural Adequacy	-	not applicable
Integrity	-	no failure at 241 minutes
Insulation	-	155 minutes

and therefore for the purpose of Building Regulations in Australia, achieved a fire-resistance level (FRL) of -/120/120.

The fire-resistance level of the specimen is applicable when the system is exposed to fire from the same direction as tested. For the purposes of AS 1530.4-2014 the results of these fire tests may be used to directly assess fire hazard, but it should be noted that a single test method will not provide a full assessment of fire hazard under all fire conditions. This certificate is provided for general information only and does not comply with regulatory requirements for evidence of compliance.

Testing Officer: Peter Gordon Date of Test: 30 July 2019

Issued on the 22nd day of August 2019 without alterations or additions.

Brett Roddy | Manager, Fire Testing and Assessments

"Copyright CSIRO 2019 ©"

Copying or alteration of this report without written authorisation from CSIRO is forbidden



This document is issued in accordance with NATA's accreditation requirements.
Accreditation No. 165 – Corporate Site No. 3625
Accredited for compliance with ISO/IEC 17025 - Testing



Certificate of Test

No. 3322

This is to certify that the element of construction described below was tested by CSIRO Infrastructure Technologies in accordance with Australian Standard 1530, Methods for fire tests on building materials, components and structures, Part 4 Fire-resistance tests of elements of construction, 2014, Section 10: Service penetrations and control joints, on behalf of:

IG6 Pty Ltd as trustee for the IG6 IP Trust
3 Skirmish Court
Victoria Point Qld 4165

A full description of the test specimen and the complete test results are detailed in the Division's report numbered FSP 2028.

Product Name: SNAP H100FWS-RR Cast-in fire collar protecting a nominal 110-mm polyvinyl chloride sandwich construction (PVC-SC) floor waste incorporating a 4-way riser with Soundlag 4525C lagging (Specimen 5)

Description: The specimen comprised an 1150-mm x 1150-mm x 120-mm thick concrete slab penetrated by a floor waste protected by a Snap Fire Systems Cast-in fire collar. The penetrated slab comprised a 120-mm thick concrete slab reinforced with a single layer of steel reinforcement providing a Fire Resistance Period (FRP) for insulation of 120 minutes in accordance with Table 5.5.1 of AS 3600:2018 - Concrete structures. The SNAP Cast-in H100FWS-RR fire collar comprised a 1.6-mm thick polypropylene casing with a 126.5-mm inner dia. and a 213-mm base flange. The 250-mm high collar casing incorporated a layer of 412-mm x 85-mm x 4-mm thick Intumescent material. The closing mechanism comprised three equally spaced 3 steel springs held with nylon fuse links. The springs were fabricated using 304 grade stainless steel wire with a dia. of 3.15-mm, with the springs acting against a layer of 316 grade stainless steel mesh measuring 460 x 83-mm as shown in drawing numbered H100FWS-RR-T dated 29 September 2017, by Snap Fire Systems Pty Ltd. The penetrating service comprised a 110-mm outside dia. PVC sandwich construction pipe with a wall thickness of 3.7-mm fitted through the collar's sleeve. The floor waste system was fitted with a chrome brass grate and ABS Puddle Flange. A 15-mm thick grout screed was laid on top of the concrete slab and finished flush with the floor grate. On the exposed side of the slab, a 4-way riser was connected to the penetrating pipe, supported by two M10 threaded rod and steel drop-in anchor to the concrete slab. On the exposed face, the 4-way riser was capped using a polyvinyl chloride sandwich construction end cap. The 4-way riser was then lagged with Pyrotec Soundlag 4525C fixed using Tesa foil tape. The floor waste gully was charged with water to the level shown in drawing titled "Specimen #5 100 PVC(SC) FWS, Lagging & H100FWS-RR", dated 15 July 2019, provided by Snap Fire Systems Pty Ltd.

Performance observed in respect of the following AS 1530.4-2014 criteria

Structural Adequacy	-	not applicable
Integrity	-	no failure at 241 minutes
Insulation	-	170 minutes

and therefore for the purpose of Building Regulations in Australia, achieved a fire-resistance level (FRL) of -/120/120.

The fire-resistance level of the specimen is applicable when the system is exposed to fire from the same direction as tested. For the purposes of AS 1530.4-2014 the results of these fire tests may be used to directly assess fire hazard, but it should be noted that a single test method will not provide a full assessment of fire hazard under all fire conditions. This certificate is provided for general information only and does not comply with regulatory requirements for evidence of compliance.

Testing Officer: Peter Gordon

Date of Test: 30 July 2019

Issued on the 22nd day of August 2019 without alterations or additions.

Brett Roddy | Manager, Fire Testing and Assessments

"Copyright CSIRO 2019 ©"

Copying or alteration of this report without written authorisation from CSIRO is forbidden



This document is issued in accordance with NATA's accreditation requirements.
Accreditation No. 165 – Corporate Site No. 3625
Accredited for compliance with ISO/IEC 17025 - Testing

References

The following informative documents are referred to in this Report:

- | | |
|----------------|---|
| AS 1530.4-2014 | Methods for fire tests on building materials, components and structures Part 4: Fire-resistance tests of elements of building construction. |
| AS 4072.1-2005 | Components for the protection of openings in fire-resistant separating elements. Part 1: Service penetrations and control joints. |
| AS 3600-2018 | Concrete structures |

CONTACT US

t 1300 363 400
+61 3 9545 2176
e enquiries@csiro.au
w www.csiro.au

YOUR CSIRO

Australia is founding its future on science and innovation. Its national science agency, CSIRO, is a powerhouse of ideas, technologies and skills for building prosperity, growth, health and sustainability. It serves governments, industries, business and communities across the nation.

FOR FURTHER INFORMATION

Infrastructure Technologies

Brett Roddy

Team Leader, Fire Testing and Assessments

t +61 2 94905449

e brett.rodny@csiro.au

w <https://www.csiro.au/en/Do-business/Services/Materials-infrastructure/Fire-safety>